

## notes

1. First Flush Capacity to be half of m<sup>2</sup> of roof i.e. 300m<sup>2</sup> roof area =150L F/Flush
2. Roof Catchment Area = \_\_\_\_\_ m<sup>2</sup>
3. First Flush system = \_\_\_\_\_ L

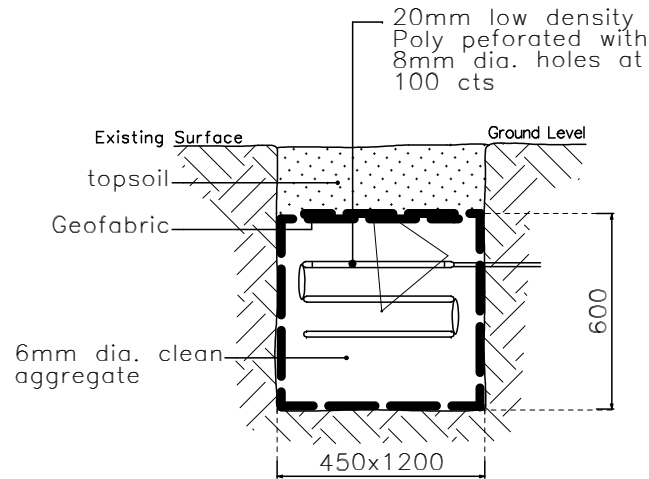

**infiltration pit**  
scale 1:20

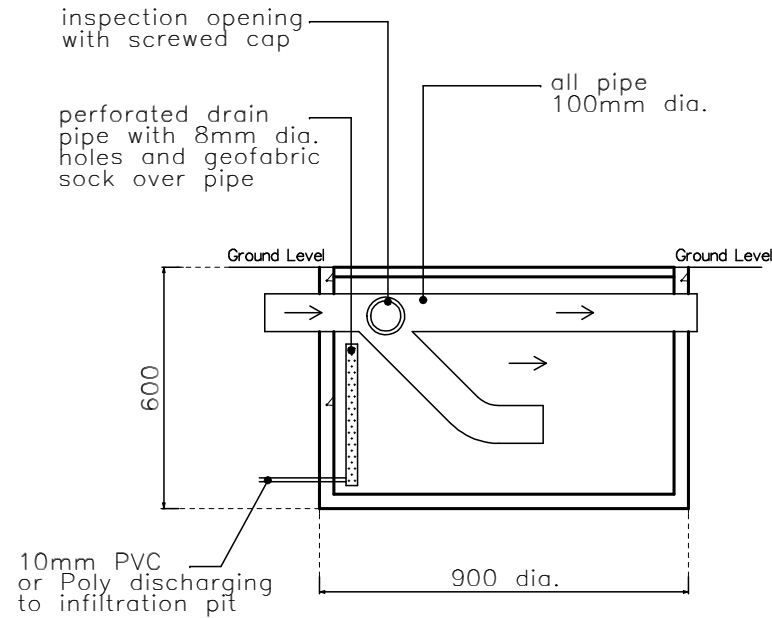

**first flush system**  
scale 1:20

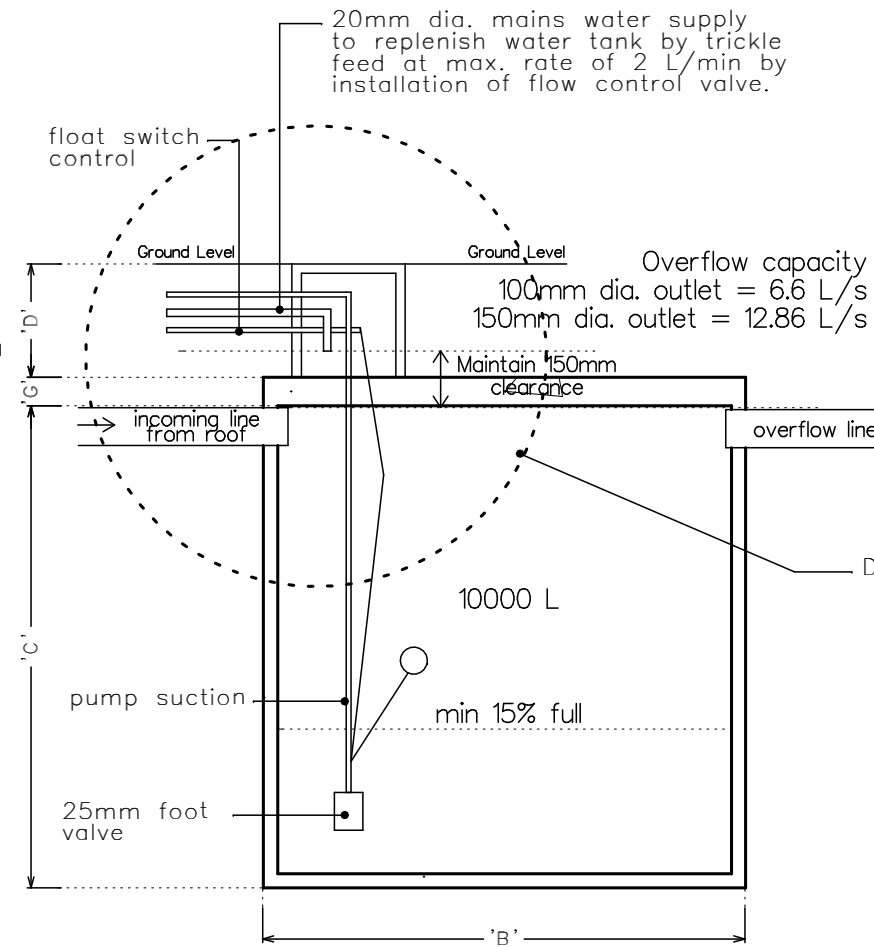

**water re-use tank details**  
scale 1:20

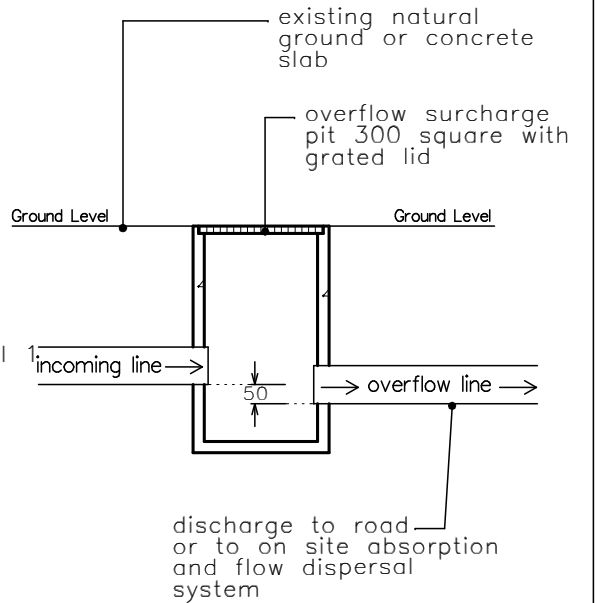

**surcharge pit**  
scale 1:20

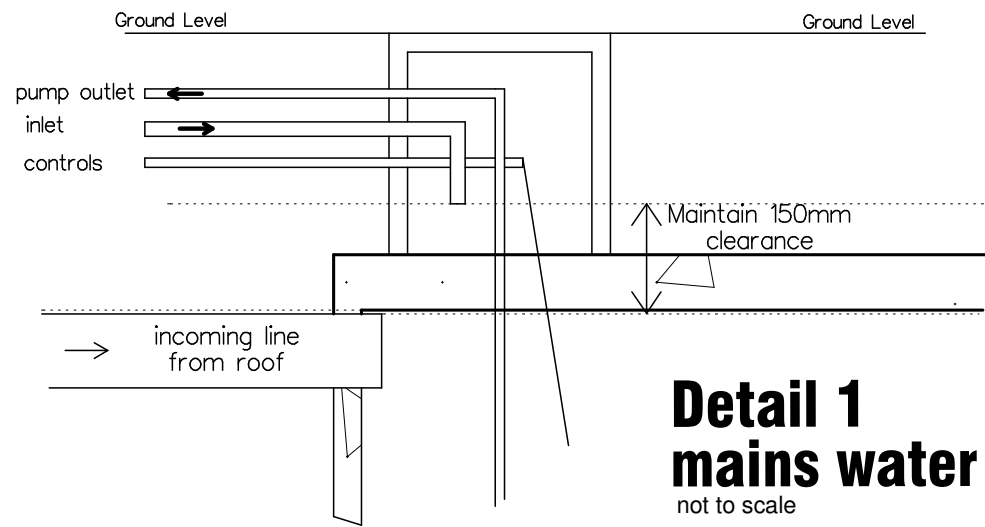

**Detail 1**  
**mains water inlet**  
not to scale

legend		10000 L concrete tank
A - O/A HEIGHT		3150mm
B - O/A DIAMETER		2550mm
C - TANK HEIGHT		2550mm
D - RISER HEIGHT		600mm
E - LIQUID DEPTH		2150mm
F - WALL THICKNESS		75mm
G - LID THICKNESS		150mm
Concrete Reinforced with Fibresteel. min. Strength 35 MPa at 28 days.		

NAME	STREET	LOCALITY
LOT		
CITY/ SHIRE		
CONNECTED TO -		
TOILETS		YES/NO
WASHING MACHINE		YES/NO
GARDEN TAPS		YES/NO
<b>Bennetts Concrete Products</b> <b>286 Princes Highway South Nowra 2541</b> <b>phone 02 4422 3861</b> <b>fax 02 4421 3861</b>		

Registered Professional Engineer 542 555  
**Mr Geoffrey C. McVey**  
 MIEAust CPEng (Civil) NPER  
 Signature.....Date.....  
 Registered on the NPER in the Category of  
**Civil**  
 National Professional Engineers Register

AMENDMENTS	
A. Removed Hot Water Service from table	11.2.05
B. Rearranged drawings to read from left to right	11.2.05
C. Drew in the air gap in the water re-use detail	11.2.05
D. Changed the height of the water inlet into the water re-use tank	11.2.05

**NOWRA**  
 PO Box 3092, North Nowra, NSW 2541  
 3/390 Princes Highway, Bomaderry  
 † (02) 4423 2822

**PICTON**  
 PO Box 138, Picton, NSW 2571  
 1st Floor, N.A.B. Building  
 cnr Argyle and Menangle Streets, Picton  
 † (02) 4677 1668  
[www.morsemcvey.com.au](http://www.morsemcvey.com.au)

DRAWING TITLE <b>RAINKEEPER RE-USE SYSTEM</b>		
CLIENT <b>BENNETTS CONCRETE</b>		
PROJECT <b>PROPOSED WATER RE-USE SYSTEM</b> <b>286 PRINCES HWY</b> <b>SOUTH NOWRA</b>		
DRAWING SCALE as shown @ A3	DRAWN M.C	CHECKED G. McVey
DATE February 2005	DRAWING No <b>04000309-02A</b>	